



A Furukawa Company

1050 Series Core Tube Entry Tools

Contents	Section
Introduction	1
Tool Description	2
Safety Precautions	3
Core Tube Splitting Procedure	4
Core Tube Ringing Procedure	5
Tool Maintenance	6

1. Introduction

1.1 This document describes the use and maintenance of OFS 1050 series core tube entry tools. The 1050 tools are used to gain fiber access in central-tube cables by slitting and ring cutting the core tube. Five different tools are available for use with the core tube ODs listed in Table 1. The 1050A, 1050D, and 1050E tools work on a single core tube size. The 1050B and 1050C tools work on two different core tube sizes as shown in Table 1.

Table 1. 1050 Core Tube Entry Tools

Tool	Comcode	Cables	Tube OD
1050A	107 757 932	Mini-LXE & Dielectric Drop Cables 1 – 18 fibers DuctSaver® FX Cables 6 – 48 fibers (6-fiber AccuRibbon®) AccuRoll™ DC Rollable Ribbon (RR) 24-48 fibers	0.16 in. (4.1 mm)
1050B	107 757 965	LightPack® LXE-ME & LXE-RL Cables 2 - 24 fibers DuctSaver® FX Cables 12 - 72 fibers (12-fiber AccuRibbon®) DuctSaver® Rollable Ribbon (RR) 48-72 fiber & AccuRoll™ DC Rollable Ribbon (RR) 60-96 fibers	0.20 in. (5.1 mm)
		LightPack® LXE-DE Cables 4 - 48 fibers LightPack® LXE-ME & LXE-RL Cables 26 - 48 fibers AccuRibbon® & AccuRibbon® TL Cables 12 - 48 fibers AccuRibbon® DC & AccuRibbon® DC TL Cables 12 - 48 fibers DuctSaver® Rollable Ribbon (RR) 84-144 fibers & AccuRoll™ DC Rollable Ribbon (RR) 144 fibers	0.24 in. (6.1 mm)
1050C	107 757 973	LightPack® Cables 50 - 96 fibers AccuRibbon® & AccuRibbon® TL Cables 60 - 144 fibers AccuRibbon® DC & AccuRibbon® DC TL Cables 60 - 144 fibers DuctSaver® Rollable Ribbon (RR) & AccuRoll™ DC Rollable Ribbon (RR) 288 fibers	0.31 in. (7.9 mm)
		AccuRibbon® Cables 156 – 240 fibers AccuRibbon® TL Cables 156 - 216 fibers AccuRibbon® DC & AccuRibbon® DC TL Cables 156-216 fibers DuctSaver® Rollable Ribbon (RR) & AccuRoll™ DC Rollable Ribbon (RR) 432 fibers	0.41 in. (10.4 mm)
1050D	107 757 981	AccuRibbon® Cables 288 – 432 fibers AccuRibbon® DC Cables 264 - 432 fibers AccuRibbon® DuctSaver® Cables 264 - 576 fibers AccuRoll™ DC Rollable Ribbon (RR) 864 fibers	0.55 in. (14.0 mm)
1050E	108 473 687	AccuRibbon® DuctSaver® Cables 744 - 864 fibers AccuRibbon® DuctSaver+ Cables 744 - 864 fibers	0.76 in. (19.3 mm)

2. Tool Description

- 2.1 The 1050 tool (Figure 1) is composed of upper and lower body sections that are opened and closed by a rotating handle. Each section contains a semicircular groove that runs along the length of the tool. Centered in this groove is an angled slot that positions a razor blade at a preset depth to cut the wall of a core tube. Each body section also contains a semicircular groove that runs perpendicular to the splitting groove. This groove is provided to ring cut the core tube.
- 2.2 The razor blades of the 1050 A, B, C, and D tools are reversible and replaceable. Locking clips are used to hold the blades in a fixed position in the tool. Each 1050 A, B, C, and D tool is provided with 20 spare razor blades. The razor blades of the 1050E tool are also replaceable (but not reversible). The blades are held in place by clamp screws. Each 1050E tool is provided with 10 spare razor blades.

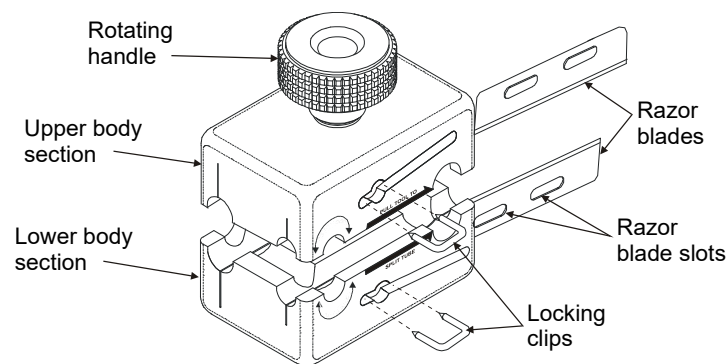

Figure 1. 1050 Series Tool

3. Safety Precautions

- Always wear safety glasses while handling optical fibers.
- Always wear work gloves when performing the following procedures.
- Always use extreme caution when handling the tool in the open position. Keep fingers away from the splitting and ring cutting grooves and the exposed edges of the razor blades.

4. Core Tube Splitting Procedure

- 4.1 The core tube splitting procedure is used to slit the core tube longitudinally and access the fibers at mid-span splice points. Refer to the appropriate cable prep documentation for sheath removal instructions.
- 4.2 Mark the length of core tube to be removed (starting point and stopping point).
- 4.3 Select the 1050 Series Core Tube Entry Tool that matches the core tube diameter.
- 4.4 Open the 1050 tool by turning the rotating handle counterclockwise.

- 4.5 The groove diameters are labeled on the top of the tool (Figure 2). Position the tool so that the proper groove is facing you. The “pull tool to split tube” direction-arrow on the side of the tool must be pointing to the right.
- 4.6 The tips of the razor blades can be seen when looking into the ring cut groove. Place the 1050 tool over the core tube and align the starting mark with the tips of the razor blades.
- 4.7 Gently squeeze the two halves of the tool over the core tube and check the alignment. When the tool is properly aligned, firmly squeeze the two halves of the tool over the core tube. Lock the two halves of the tool together by turning the handle clockwise until the tool is completely closed.
- 4.8 Pull the tool along the core tube in the direction of the splitting arrow until the stopping mark is centered in the ring cut groove. Maintain the core tube in a straight alignment as the 1050 tool is pulled along the length of the tube. If the tool is difficult to pull, loosen the rotating handle in ¼ turn increments and try again.
- 4.9 Remove the tool by turning the rotating handle counterclockwise. The core tube is now ready for the ring cut operation.

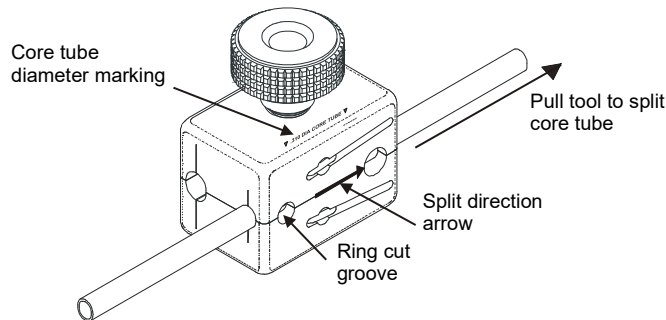

Figure 2. Core Tube Splitting

5. Core Tube Ringing Procedure

- 5.1 The core tube ringing procedure is used to score the core tube circumferentially for both mid-span and end-prep fiber access. After scoring the core tube, the tube is flexed to separate it at the score mark.
- 5.2 Open the 1050 tool by turning the rotating handle counterclockwise.
- 5.3 The ring-cutting groove diameters are labeled on the side of the tool (Figure 3). Place the appropriate ring-cutting groove over core tube and align the razor blades with the mark on the tube.
- 5.4 Gently squeeze the two halves of the 1050 tool over the core tube and check the alignment. Close the 1050 tool by turning the rotating handle clockwise until the tool is completely closed.
- 5.5 Rotate the tool one-half turn around the core tube. The ring cut operation cuts approximately 90 percent through the tube wall.

- 5.6 Remove the tool by turning the rotating handle counterclockwise. Flex and snap the core tube at the ring cut to separate the core tube. For end-prep access, the core tube can now be removed to expose the fibers.
- 5.7 For mid-span access, repeat the ring-cutting procedure at the second mark on the core tube. Separate the core tube along the longitudinal slit and remove from the fibers. If the slitting cuts did not go all the way through the tube wall, gently squeeze the tube along the slit to snap the tube into two pieces.

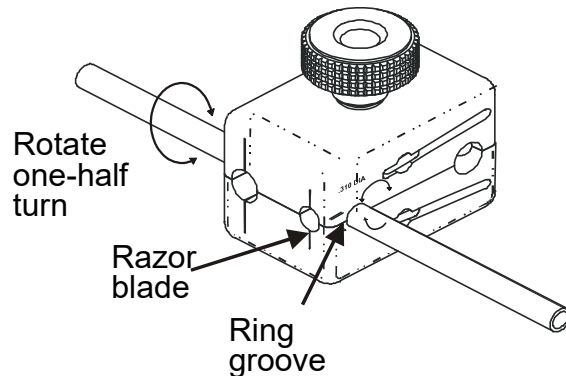

Figure 3. Ring Cut Core Tube

6. Tool Maintenance

- 6.1 There are no adjustments or replaceable parts other than the razor blades. Replacement blades for the 1050 A, B, C, and D tools may be ordered under Comcode 107 482 697 (20 blades). Replacement blades for the 1050E tool are ordered under Comcode 108 600 818 (10 blades).
- 6.2 Paragraphs 6.3 – 6.10 describe blade replacement for the 1050 A, B, C, and D tools. Blade replacement for the 1050E tool is described in paragraphs 6.11 – 6.17.
- 6.3 Open the 1050 tool by turning the rotating handle counterclockwise as far as it will turn.
- 6.4 Use a small screwdriver or needle nose pliers to remove the locking clip (Figure 4).
- 6.5 Use the same tool or the locking clip to slide the razor blade out of the tool.
- 6.6 Use a business card or similar material to clean any debris from the razor blade slot of the tool.
- 6.7 If the razor blade is being reversed, turn the razor blade around, slide the blade into position, align the slots in the blade with the holes in the tool, and replace the locking clip.
- 6.8 If the razor blade is being replaced, slide the new blade into position, align the slots in the blade with the holes in the tool, and replace the locking clip.
- 6.9 Ensure that the clip is flush with the side of the tool.

6.10 Repeat Steps 6.2 through 6.9 for each blade being reversed or replaced. After all blades have been reversed or replaced, close the tool by turning the rotating the handle clockwise.

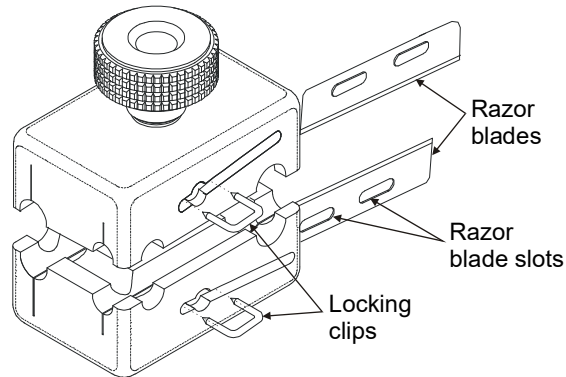

Figure 4. Razor Blade Replacement or Reversal for the 1050 A, B, C, and D Tools

6.11 The following paragraphs describe blade replacement for the 1050E tool (Figure 5). Repeat Steps 6.12 through 6.15 for each blade being replaced.

6.12 Use the hex wrench (provided in kit) to remove the clamp screw.

6.13 Remove the blade clamp and cutting blade from the tool.

6.14 Place a new cutting blade into the recessed pocket.

6.15 Replace the blade clamp and tighten the clamp screw.

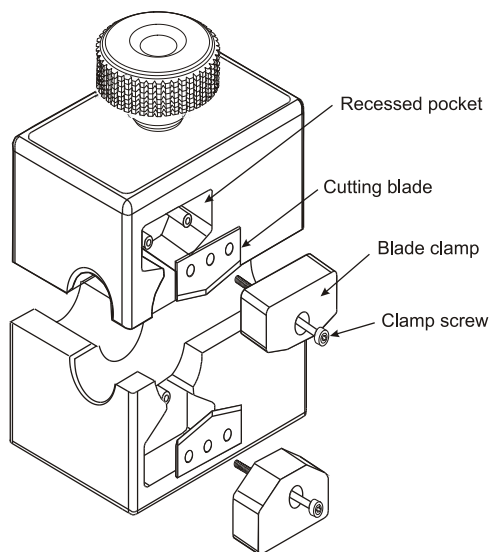

Figure 5. Blade Replacement for the 1050E Tool